

**MANDATORY****SEL-24-11****TITLE**

ELECTRICAL POWER - TRANSMITTAL OF CONTINENTAL AEROSPACE TECHNOLOGIES CRITICAL SERVICE BULLETIN CSB19-06

**EFFECTIVITY****CESSNA MODELS**

<b>MODEL</b>	<b>SERIAL NUMBERS</b>
T240	T24000001 thru T24002146
300 (LC40-550FG)	40001 thru 40079
350 (LC42-550FG)	42001 thru 42084, 42501 thru 42569, 421001 thru 421020
400 (LC41-550FG)	41002 thru 41108, 41501 thru 41533, 41563 thru 41800, 411001 thru 411161

**BEECHCRAFT MODELS**

<b>MODEL</b>	<b>SERIAL NUMBERS</b>
E33A	CE-180 thru CE-289
E33C	CJ-1 thru CJ-25
F33A	CE-290 thru CE-1791
F33C	CJ-26 thru CJ-179
35-C33A	CE-1 thru CE-179
S35	D-7140, D-7310 thru D-7976
V35	D-7977 thru D-8598
V35A	D-8599 thru D-9068
V35B	D-9069 thru D-10403
36	E-1 thru E-184
A36	E-185 thru E-3629, E-3631 thru E-3635
A36TC	EA-1 thru EA-241, EA-243 thru EA-272
B36TC	EA-242, EA-273 thru EA-697

**REASON**

It is possible that the alternator is installed with a castellated hex-nut that does not have torque flush with the thrust washer. This condition can cause engine damage or unexpected loss of engine power. Refer to Continental Aerospace Technologies Critical Service Bulletin CSB19-06.

**DESCRIPTION**

This service document transmits Continental Aerospace Technologies Critical Service Bulletin CSB19-06.

October 4, 2021

SEL-24-11  
Page 1 of 3

Textron Aviation Customer Service, P.O. Box 7706, Wichita, KS 67277, U.S.A. 1-316-517-5800

This document contains technical data and is subject to U.S. export regulations. This information has been exported from the United States in accordance with export administration regulations. Diversion contrary to U.S. law is prohibited. ECCN: 9E991

**MANDATORY****SEL-24-11****COMPLIANCE**

MANDATORY. Refer to Continental Aerospace Technologies Critical Service Bulletin CSB19-06 for compliance information.

A service document published by Textron Aviation may be recorded as *completed* in an aircraft log only when the following requirements are satisfied:

- 1) The mechanic must complete all of the instructions in the service document, including the intent therein.
- 2) The mechanic must correctly use and install all applicable parts supplied with the service document kit. Only with written authorization from Textron Aviation can substitute parts or rebuilt parts be used to replace new parts.
- 3) The mechanic or airplane owner must use the technical data in the service document only as approved and published.
- 4) The mechanic or airplane owner must apply the information in the service document only to aircraft serial numbers identified in the *Effectivity* section of the document.
- 5) The mechanic or airplane owner must use maintenance practices that are identified as acceptable standard practices in the aviation industry and governmental regulations.

No individual or corporate organization other than Textron Aviation is authorized to make or apply any changes to a Textron Aviation-issued service document or flight manual supplement without prior written consent from Textron Aviation.

Textron Aviation is not responsible for the quality of maintenance performed to comply with this document, unless the maintenance is accomplished at a Textron Aviation-owned Service Center.

**CONSUMABLE MATERIAL**

No specialized consumable materials are required to complete this service document.

**TOOLING**

No specialized tooling is required to complete this service document.

**REFERENCES**

Continental Aerospace Technologies Critical Service Bulletin CSB19-06, Original Issue (or latest revision)

Hartzell Engine Technologies Alert Service Bulletin 081A, REV A (or latest revision)

**PUBLICATIONS AFFECTED**

None

**ACCOMPLISHMENT INSTRUCTIONS**

1. Review the Continental Aerospace Technologies Critical Service Bulletin CSB19-06 and the Hartzell Engine Technologies Alert Service Bulletin 081A.
  - A. If it can be determined that the alternator is not part of the affected lot, or that previous compliance can be verified with aircraft or engine maintenance records, no further action is required. Go to Step 3.
  - B. If it is suspected that the alternator is part of the affected lot, or that compliance with the aircraft or engine maintenance records can not be verified, further action is required. Go to Step 2.
2. Complete the Continental Aerospace Technologies Critical Service Bulletin CSB19-06 and the Hartzell Engine Technologies Alert Service Bulletin 081A.
3. Make an entry in the airplane logbook that states compliance and method of compliance with this service document.

**MANDATORY**

**SEL-24-11**

## MATERIAL INFORMATION

For parts information, refer to Continental Aerospace Technologies Critical Service Bulletin CSB19-06 Original Issue (or latest revision).



**TITLE**

ELECTRICAL POWER - TRANSMITTAL OF CONTINENTAL AEROSPACE TECHNOLOGIES CRITICAL SERVICE BULLETIN CSB19-06

**TO:**

Aircraft Owner of the Cessna and Beechcraft Models as follows:

**CESSNA MODELS**

T240, 300 (LC40-550FG), 350 (LC42-550FG), 400 (LC41-550FG)

**BEECHCRAFT MODELS**

E33A, E33C, F33A, F33C, 35-C33A, S35, V35, V35A, V35B, 36, A36, A36TC, B36TC

**REASON**

It is possible that the alternator is installed with a castellated hex-nut that does not have torque flush with the thrust washer. This condition can cause engine damage or unexpected loss of engine power. Refer to Continental Aerospace Technologies Critical Service Bulletin CSB19-06 Original Issue (or latest revision).

**COMPLIANCE**

MANDATORY. Refer to Continental Aerospace Technologies Critical Service Bulletin CSB19-06 Original Issue (or latest revision) for compliance information.

**LABOR HOURS**

For planning purposes only:

WORK PHASE	LABOR-HOURS
Inspection	1.0
Modification	1.0

**MATERIAL AVAILABILITY**

Refer to the Continental Aerospace Technologies Critical Service Bulletin CSB19-06 Original Issue (or latest revision).

**WARRANTY**

This service document is *mandatory*. Eligible airplanes may qualify for parts and labor coverage to the extent noted in the *Labor Hours* and *Material Availability* sections of this document.

October 4, 2021

SEL-24-11  
Page 1 of 2

Textron Aviation Customer Service, P.O. Box 7706, Wichita, KS 67277, U.S.A. 1-316-517-5800

This document contains technical data and is subject to U.S. export regulations. This information has been exported from the United States in accordance with export administration regulations. Diversion contrary to U.S. law is prohibited. ECCN: 9E991

**Eligibility:** Airplanes identified within the serial number effectivity of this service document must have active Airframe warranty coverage on the original issue date of this document and the coverage must be active on the day the work is accomplished.

**Parts Coverage:** Textron Aviation-owned and Textron Aviation-authorized Service Facilities, operators, or other maintenance facilities may submit a claim for the parts required to accomplish this service document as defined in the *Material Availability* section of this document.

**Labor Coverage:** Textron Aviation-owned and Textron Aviation-authorized Service Facilities rated to perform maintenance on the specific model of Cessna or Beechcraft Aircraft may submit a claim for the labor necessary to accomplish this service document as defined in the *Labor Hours* section of this document.

**Credit Application:** After this service document has been accomplished, a claim must be submitted to Textron Aviation within 30 days of the service document completion. Claims for compliance of this service document are to be filed as a W4 type claim.

Please submit your claim form online at [ww2.txtav.com/Parts](http://ww2.txtav.com/Parts) or email the completed Textron Aviation Claim Form to [warranty@txtav.com](mailto:warranty@txtav.com). If submitted on-line a Return Authorization will be provided. If a paper claim is submitted your claim will be entered into the system and a Return Authorization will be sent to you.

The Return Authorization must accompany any required return parts (see *Material Availability*), to the point of purchase.

Parts to be returned to Textron Aviation Parts Distribution should be forwarded to:

Textron Aviation Parts Distribution  
Warranty Administration  
285 South Greenwich Road  
Bldg B89, Docks 1-4  
Wichita, KS 67206  
USA

**Expiration:** October 4, 2022 (after this date the owner/operator assumes the responsibility for compliance costs)

Textron Aviation reserves the right to void continued airplane warranty coverage for the parts affected by this service document until the service document is accomplished.

**NOTE:** As a convenience, service documents are now available online to all our customers through a simple, free-of-charge registration process. If you would like to sign up, please visit the Customer Access link at [www.txtavsupport.com](http://www.txtavsupport.com) to register.

COMPLIANCE NECESSARY TO MAINTAIN SAFETY

TECHNICAL PORTIONS  
FAA APPROVED

- SUBJECT:** Hartzell Engine Technologies (HET) Alert Service Bulletin (ASB) No. 081A
- PURPOSE:** To notify owners, operators, distributors, and maintenance facilities of inspection criteria for affected Hartzell alternators; Continental P/Ns 641668, 641670, and 656802.
- COMPLIANCE:** Compliance may be required prior to further flight. Reference attached Hartzell Engine Technologies (HET) Alert Service Bulletin (ASB) No. 081A.
- MODELS**
- AFFECTED:** New and rebuilt Continental GTSIO-520-C, N; IO-520-B, BA, BB, C, CB; IO-550-A, B, C, G, N, P, R, IOF-550-B, C, N; TSIO-520-B, BB, D, DB, E, EB, NB, UB; TSIO-550-B, C, E, G, J, K, N; TSIOF-550-D, J, K, P and TSIOL-550-B aviation gasoline (AvGas) engines.

Listed Continental engine models may have been equipped with affected Hartzell Engine Technologies alternator models from the Continental factory or as Continental-supplied service spares. Additional Continental engine models may have affected Hartzell Engine Technologies alternator models installed under authority Airplane Type Design, PMA, or STC not controlled by Continental Aerospace Technologies.

---

---

## I. GENERAL INFORMATION

Hartzell Engine Technologies LLC (HET) has issued Alert Service Bulletin (ASB) No. 081A requiring the inspection of an identified alternator castellated hex-nut shipped between 05 January 2011 and 21 May 2019. Reference Hartzell Engine Technologies Alert Service Bulletin (ASB) No. 081A for the applicable alternators (serial number(s) and shipment date(s)).

Continental Aerospace Technologies™ (Continental®) recommends compliance with HET Alert Service Bulletin (ASB) No. 081A.

## II. WARRANTY

Direct all questions regarding the actions required by the attached Alert Service Bulletin to:

Hartzell Engine Technologies LLC  
2900 Selma Highway  
Montgomery, AL 36108  
Phone: +1-334-386-5441  
FAX: +1-334-386-5410  
E-mail: techsupport@HartzellEngineTech.com

*Intentionally Left Blank*

---

**ISSUED**  
2019/11/19

**REVISED**  
--



**DOC NO** REVISION  
CSB19-06

**PAGE**  
2 of 2





2900 Selma Highway  
Montgomery, AL 36108 USA  
Tel: 334-386-5400 Fax: 334-386-5450

# **ALERT SERVICE BULLETIN**

**ALERT SERVICE BULLETIN No. 081 Rev. A**

## **Alternator Castellated Hex-Nut Inspection**

1. This page transmits the revision of Alert Service Bulletin (ASB) 081 Rev. New to ASB 081 Rev. A, dated September 19, 2019.
  - A. ASB 081 Rev. New, dated August 06, 2019
  - B. ASB 081 Rev. A, dated September 19, 2019
2. FAA approval has been obtained on technical data in this publication that affects type design.
3. Changes are shown by a change bar in the left or right margin coinciding with the change on the affected page.
4. This revision is issued to change the following:
  - A. Correct part number typo, Table 1, Materials Required:
    - (1) Change thrust washer P/N 63097 to 63091 (Table 1, ITM# 3).
  - B. Revise 3.B.2.(c) to reflect change to Figure 4:
    - (1) Change to: Hex-nut (1) is roll-stamped with the letters “**AD**”.
  - C. Add task 3.B.(6) for clarification:
    - (1) Inspect drive coupling (4) in accordance with applicable service instructions.
  - D. Change Figure 4 from Machined Groove to Roll-Stamped “AD” and update illustration.



2900 Selma Highway  
Montgomery, AL 36108 USA  
Tel: 334-386-5400 Fax: 334-386-5450

# ALERT SERVICE BULLETIN

ALERT SERVICE BULLETIN No. 081 Rev. A

## Alternator Castellated Hex-Nut Inspection

### 1. Planning Information

#### A. Effectivity

- (1) Plane-Power alternators P/N ALT-9522(R), ALV-9510(R), ALV-9610, ALX-9524(R), C14-100(S), C28-150(S), ES-6024D, and ES-10024 manufactured by Hartzell Engine Technologies (HET) and shipped between 05 January 2011 and 21 May 2019 are affected by this Alert Service Bulletin (ASB).
- (2) Engine model/series affected by this ASB are shown in Table 2.

**NOTE:** Table 2 is for reference only and is not an all-inclusive list of engines affected by this ASB. It is the responsibility of the owner/operator to verify whether an affected alternator may be installed.

**WARNING:** DO NOT USE OBSOLETE OR OUTDATED INFORMATION. PERFORM ALL INSPECTIONS OR WORK IN ACCORDANCE WITH THE MOST RECENT REVISION OF THIS SERVICE BULLETIN. INFORMATION CONTAINED HEREIN MAY BE SIGNIFICANTLY CHANGED FROM EARLIER REVISIONS. FAILURE TO COMPLY WITH THIS SERVICE BULLETIN OR THE USE OF OBSOLETE INFORMATION MAY CREATE AN UNSAFE CONDITION THAT MAY RESULT IN DEATH, SERIOUS BODILY INJURY, AND/OR SUBSTANTIAL PROPERTY DAMAGE. REFER TO THE PLANE-POWER WEBSITE, [WWW.PLANEPOWER.AERO](http://WWW.PLANEPOWER.AERO), FOR THE MOST RECENT REVISION LEVEL OF THIS ALERT SERVICE BULLETIN.

#### B. Concurrent Requirements

- (1) None

#### C. Reason

- (1) Alternators listed in section 1.A could contain a castellated hex-nut (1, Figure 1) that does not torque flush with the thrust washer (3). This condition could compromise the integrity of the drive coupling retention system.
  - (a) Loss of drive coupling retention may result in engine damage and/or unexpected loss of engine power.
- (2) This ASB is to advise the field of a known condition and to supply inspection criteria to identify affected alternators.

#### D. Description

- (1) This Alert Service Bulletin provides Instructions for Continued Airworthiness (ICA).

# **ALERT SERVICE BULLETIN**

**ALERT SERVICE BULLETIN No. 081 Rev. A**

## **Alternator Castellated Hex-Nut Inspection**

### E. Compliance

- (1) **IMMEDIATE:** If a loss of alternator output or erratic output indication occurs during flight, land as soon as practicable. Comply with this ASB prior to further flight.
- (2) Compliance with section 3.A of this ASB is required within fifty (50) hours time-in-service after the effective date of this ASB or at the next scheduled annual inspection, whichever occurs first.
- (3) For affected alternators in inventory, return within 30 days from the original issue date of this Alert Service Bulletin or prior to installation, whichever occurs first.
- (4) Compliance with the Accomplishment Instructions is the terminating action for this ASB.

### F. Approval

- (1) FAA acceptance has been obtained on the technical data in this publication that affects type design.

### G. Manpower

- (1) Up to one (1) hour labor for alternator removal, inspection, and alternator installation.
- (2) Up to two (2.0) hours labor for alternator removal, inspection, replacement of the castellated hex-nut, and alternator installation.

### H. References

- (1) Continental Aerospace Technologies' Manual M-0, *Standard Practice for Spark Ignited Engines*.
- (2) HET Manual P/N OE-A2, *Alternator and Starter Overhaul Manual*, Rev. 08 or later FAA approved revision.
- (3) Applicable Aircraft Service Instructions or Maintenance Manual.
- (4) Applicable Aircraft AFM or POH.
- (5) Continental Aerospace Technologies' Engine Installation & Operation Manual.
- (6) Continental Aerospace Technologies' Engine Maintenance/Overhaul Manual and Service Publications.

### I. Weight and Balance

- (1) No Change

## **2. Materials Required**

- A. Refer to Table 1 - Materials Required.

# ALERT SERVICE BULLETIN

ALERT SERVICE BULLETIN No. 081 Rev. A

## Alternator Castellated Hex-Nut Inspection

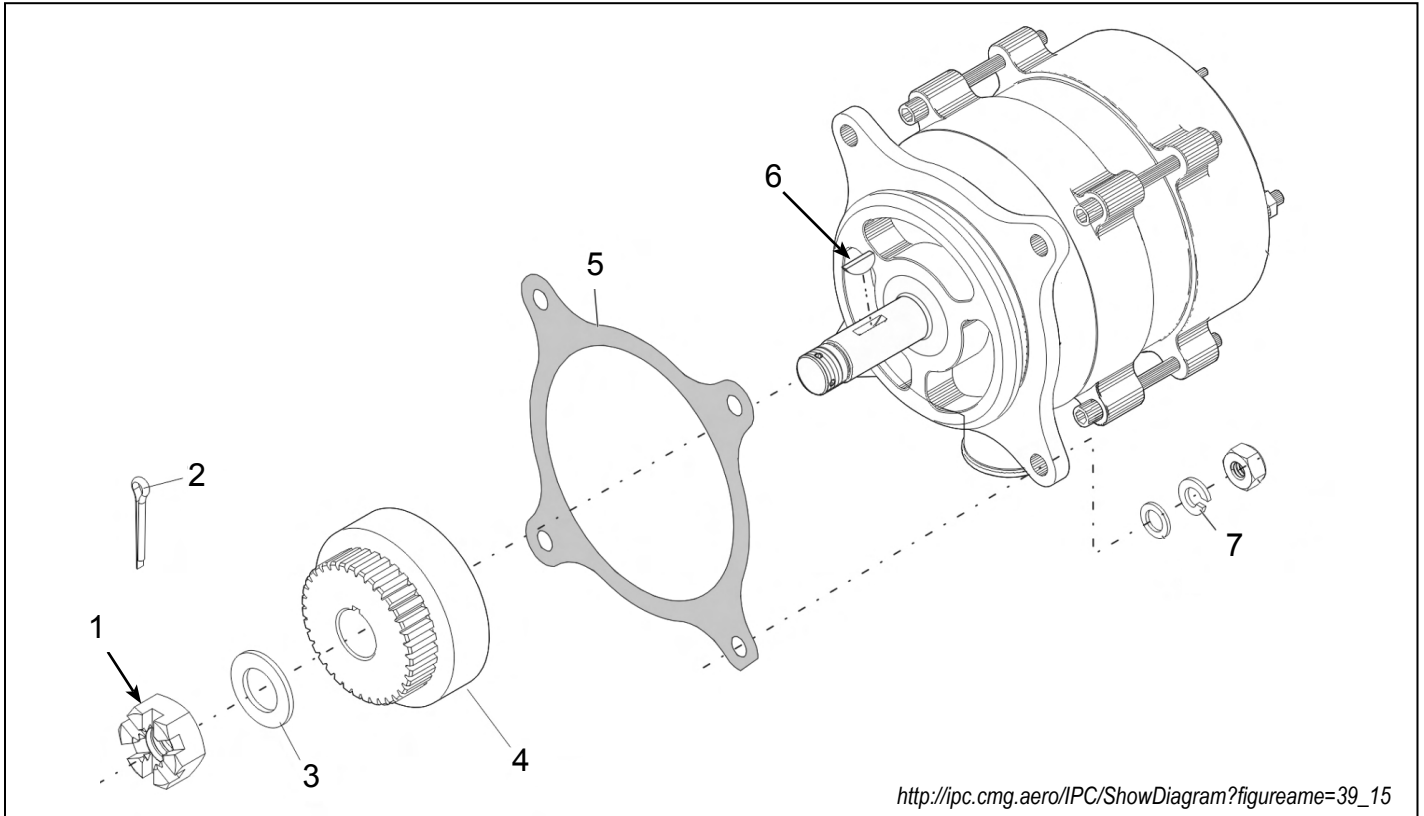

Figure 1 - Alternator, Typical - Continental Aerospace Technologies

ITM #	P/N	Description	Quantity
1	8X-4075	Nut, Castellated Hex <sup>†</sup>	1
2	MS24665-302	Pin, Cotter*	1
3	630691	Washer, Thrust*	1
5	653981	Gasket, Mounting*	1
6	X-0260	Key, Woodruff, #5 <sup>†</sup>	1
7	MS35338-45	Washer, Lock-Spring .3125*	4

\* Part numbers are typical, reference current Continental IPC. Parts available from Continental Aerospace Technologies.  
<sup>†</sup> Parts available from Hartzell Engine Technologies.

Table 1- Materials Required (Refer to Figure 1)

# **ALERT SERVICE BULLETIN**

**ALERT SERVICE BULLETIN No. 081 Rev. A**

## **Alternator Castellated Hex-Nut Inspection**

### **3. Accomplishment Instructions**

**WARNING 1:** THIS PROCEDURE MUST BE PERFORMED BY COMPETENT AND QUALIFIED PERSONNEL WHO ARE FAMILIAR WITH THE AIRFRAME AND ENGINE SYSTEM MAINTENANCE. FAILURE TO DO SO MAY RESULT IN PHYSICAL INJURY, EQUIPMENT DAMAGE AND/OR ECONOMIC LOSS.

**WARNING 2:** DO NOT USE OBSOLETE OR OUTDATED INFORMATION. PERFORM ALL INSPECTIONS OR WORK IN ACCORDANCE WITH THE MOST RECENT REVISION OF THIS SERVICE BULLETIN. INFORMATION CONTAINED HEREIN MAY BE SIGNIFICANTLY CHANGED FROM EARLIER REVISIONS. FAILURE TO COMPLY WITH THIS SERVICE BULLETIN OR THE USE OF OBSOLETE INFORMATION MAY CREATE AN UNSAFE CONDITION THAT MAY RESULT IN DEATH, SERIOUS BODILY INJURY, AND/OR SUBSTANTIAL PROPERTY DAMAGE. REFER TO THE PLANE-POWER WEBSITE FOR THE MOST RECENT REVISION LEVEL OF THIS ALERT SERVICE BULLETIN, [WWW.PLANEPOWER.AERO](http://WWW.PLANEPOWER.AERO).

**CAUTION:** REFER TO THE APPLICABLE MANUFACTURER'S MAINTENANCE MANUALS OR SERVICE INSTRUCTIONS TO GAIN ACCESS TO THE AIRFRAME OR ALTERNATOR. IN ADDITION, ANY PREFLIGHT OR IN-FLIGHT OPERATIONAL CHECKS REQUIRE USE OF THE APPROPRIATE AFM OR POH.

#### **A. Inspection**

- (1) If previous compliance cannot be verified through aircraft or engine maintenance records, use the same references to determine if an affected alternator has been installed. Refer to section 1.A, Effectivity.
- (2) If effectivity of the alternator cannot be established using aircraft or engine maintenance records, utilize the applicable aircraft maintenance manual to gain access to the alternator and inspect the alternator part number against the affected part numbers found in section 1.A of this ASB.
  - (a) If the alternator part number is affected per section 1.A, continue to 3.B. - Corrective Action.
  - (b) If the alternator part number is not affected per section 1.A, continue to 3.C. - Return to Service.

# ALERT SERVICE BULLETIN

ALERT SERVICE BULLETIN No. 081 Rev. A

## Alternator Castellated Hex-Nut Inspection

### B. Corrective Action

- (1) Remove the alternator from the engine in accordance with the latest revision of the aircraft and/or engine manufacturer's maintenance manual.
- (2) Inspect castellated hex-nut (1). If one the following indicators is present, the alternator is in compliance with this ASB. Refer to Figures 3 thru 5.
  - (a) Hex-nut (1) is laser etched with the letter "H";
  - (b) Hex-nut (1) is stamped with a center-punch;
  - (c) Hex-nut (1) is roll-stamped with the letters "AD".
- (3) If any indicator stated above **is not** present, proceed to 3.B.(4). If one of the indicators stated above **is** present, continue to 3.B.(8).
- (4) Using a .002 in. (.0508 mm) feeler-gauge, measure the gap between the nut thrust face and the thrust washer at each of the six hex-nut flats. Refer to Figure 6.

**NOTE:** **Do Not** remove cotter pin (2) or break torque prior to conducting measurements.

- (a) If the measurement at any nut flat is  $\geq$  .002 in. (.0508 mm), continue to 3.B.(5).
- (b) If the measurement at each nut flat is  $<$  .002 in. (.0508 mm), no corrective action is required.
  - 1) Using an automatic center punch, punch the face of the hex-nut (1) so that it will be easily identified for future reference (Refer to Figure 5). Continue to 3.B.(8).

**CAUTION:** THE CENTER PUNCH HAS THE POTENTIAL TO SLIP AND DAMAGE THE THREADS OF THE ALTERNATOR ROTOR SHAFT. USE CAUTION WHILE CENTER-PUNCHING THE CASTELLATED HEX-NUT TO AVOID CONTACT WITH THREADS.

- (5) Remove and discard from alternator; cotter pin (2), castellated hex-nut (1), thrust washer (3), and woodruff key (6). Refer to Figure 1.
- (6) Inspect drive coupling (4) in accordance with applicable service instructions.
- (7) Install new replacement components not affected by this ASB onto the alternator in accordance with applicable engine manufacturer's maintenance manual. Refer to Table 1 - Materials Required.

**NOTE:** Thrust washer (3) must be replaced per Continental Aerospace Technologies' M-0 Manual, *Standard Practice for Spark Ignited Engines*.

# **ALERT SERVICE BULLETIN**

**ALERT SERVICE BULLETIN No. 081 Rev. A**

## **Alternator Castellated Hex-Nut Inspection**

- (8) Install the alternator onto the engine in accordance with applicable engine manufacturer's maintenance manual.
- (9) Reconnect alternator electrical connections and cooling hardware in accordance with applicable aircraft manufacturer's maintenance manual.

### **C. Return to Service**

- (1) Close all access doors and covers opened to gain access to the alternator in accordance with applicable airframe and/or engine maintenance manual.

### **D. Maintenance Record**

- (1) Make an appropriate logbook entry noting compliance with this Alert Service Bulletin.

## **4. Contact Information**

### **A. Contact HET Product Support for all communications regarding the technical content of this Service Bulletin.**

- (1) Phone +1.334.386.5400 (Option 2)
- (2) Fax +1.334.386.5450
- (3) E-mail at [techsupport@HartzellEngineTech.com](mailto:techsupport@HartzellEngineTech.com)
- (4) Address

Hartzell Engine Technologies LLC - ATTN: Product Support  
2900 Selma Highway  
Montgomery, AL 36108  
USA

# ALERT SERVICE BULLETIN

ALERT SERVICE BULLETIN No. 081 Rev. A

## Alternator Castellated Hex-Nut Inspection

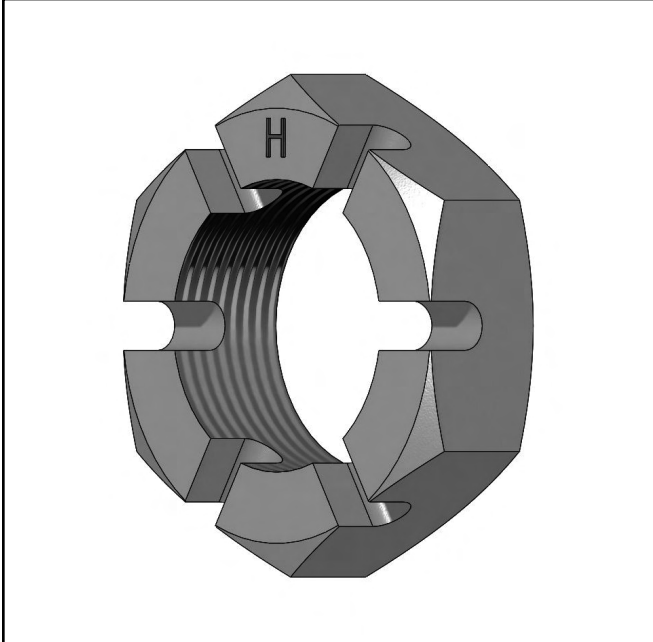

Figure 3 - Laser Etched "H"

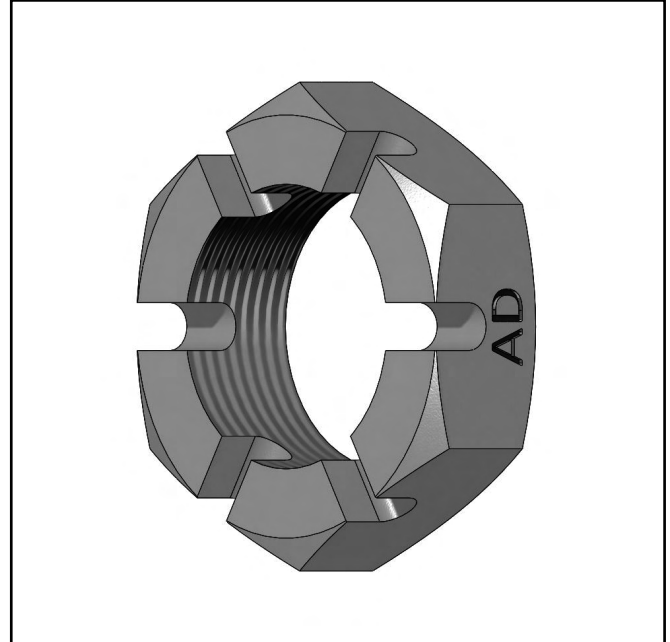

Figure 4 - Roll-Stamped "AD"

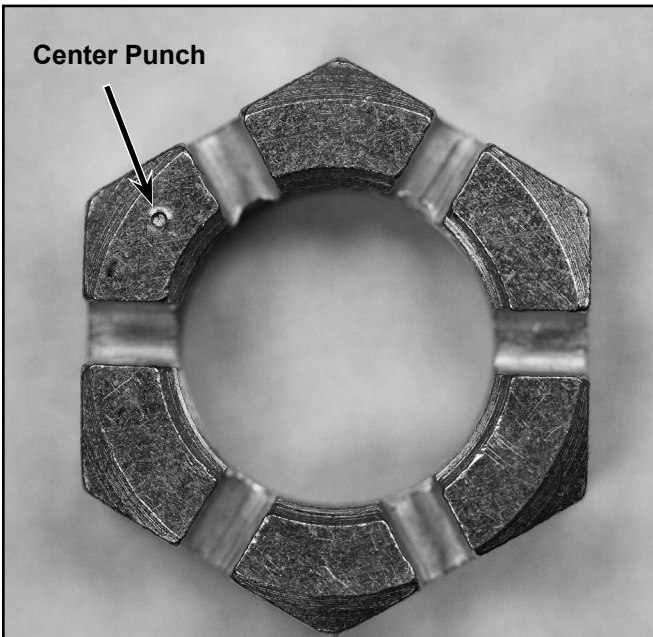

Figure 5 - Center-Punch Mark

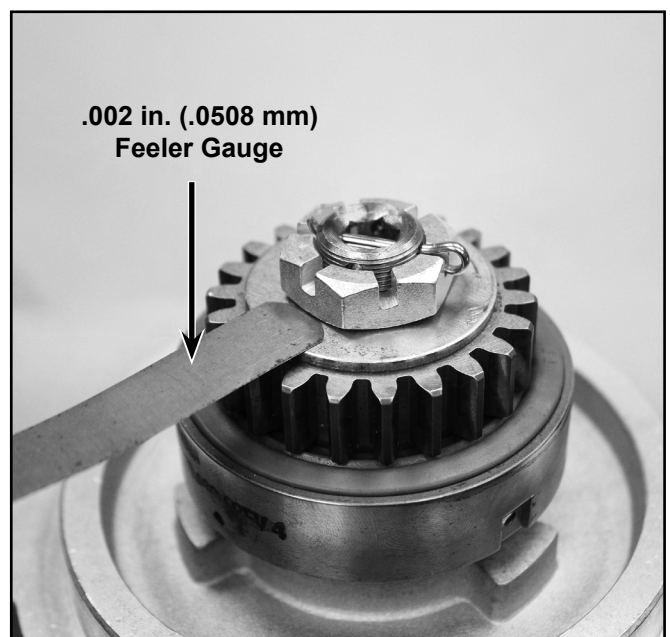

Figure 6 - Gap Measurement



# ALERT SERVICE BULLETIN

ALERT SERVICE BULLETIN No. 081 Rev. A

## Alternator Castellated Hex-Nut Inspection

Plane-Power Alternator P/N	Continental P/N	Engine Make	Engine Model/Series
ALT-9522 ALT-9522R	641668	Continental	GTSIO-520-C, -D, -F, -G, -H, -K, -L, -M, -N, -R
			IO-520-A, -B, -BA, -BB, -C, -CB, -M, -MB
			IO-550-A, -B, -C, -G, -N, -P, -R
			TSIO-520-B, -BB, -BE, -D, -DB, -E, -EB, -J, -JB, -K, -KB, -L, -LB, -N, -NB, -U, -UB, -VB, -WB
			TSIO-550-A, -B, -C, -E
			TSIOL-550-A, -B, -C
ALV-9510 ALV-9510L ALV-9510R	-	Continental	GTSIO-520-C
			IO-520-A
			TSIO-520-E
ALV-9610	-	Continental	GTSIO-520-C, D, F, G, H, K, L, M, N, R
			IO-520-A, B, BA, BB, C, CB, M, MB
			IO-550-A, B, C, G, N, P, R
			TSIO-520-B, BB, BE, D, DB, E, EB, J, JB, K, KB, L, LB, N, NB, U, UB, VB, WB
			TSIO-550-A, B, C, E
			TSIOL-550-A, B, C
ALX-9524 ALX-9524R	641670	Continental	IO-520-B, -C
C14-100 C14-100S	-	Continental	IO-520-B, -BA, -BB, -C, -CB
			IO-550-A, -B, -G, -N, -P, -R
			IOF-550-B, -C
			TSIO-520-D, -DB, -NB
			TSIO-550-B, -C, -E
			TSIOL-550-B

**Table 2 - Alternator / Engine Effectivity (Cont'd→)**

# ALERT SERVICE BULLETIN

ALERT SERVICE BULLETIN No. 081 Rev. A

## Alternator Castellated Hex-Nut Inspection

Plane-Power Alternator P/N	Continental P/N	Engine Make	Engine Model/Series
C28-150 C28-150S	-	Continental	GTSIO-520-C, -D, -E, -F, -H, -K, -L, -M, -N
			IO-520-B, -BA, -BB, -C, -CB, -M, MB, -N, -NB
			IO-550-A, -B, -C, -G, -N, -P, -R
			IOF-550-B, -C, -N, -P, -R
			TSIO-520-B, -BB, -BE, -D, -DB, -E, -EB, -J, -JB, -K, -KB, -L, -LB, -N, -U, -NB, -UB, -VB, -WB
			TSIO-550-A, -B, -C, -E, -G, -K
			TSIOF-550-D, -J, -K
			TSIOL-550-A, -B, -C
ES-6024D	-	Continental	GTISO-520-C, -D, -H, -K, -L, -M, -N
			IO-520-B, -BA, -BB, -C, -CB, -M, -MB
			IO-550-A, -B, -C, -G, -N, -P, -R
			TSIO-520-B, -BB, -BE, -D, -DB, -E, -EB, -J, -JB, -K, -KB, -L, -LB, -N, -NB, -U, -UB, -VB, -WB
			TSIO-550-A, -B, -C, -E
ES-10024	656802	Continental	IO-550-A, -B, -C, -D, -E, -F, -G, -L, -N, -P, -R
			IOF-550-B, -C, -D, -E, -F, -L, -N, -P, -R

(Cont'd) **Table 2 - Alternator / Engine Effectivity**

# Alert Service Bulletin Appendix

## Alert Service Bulletin No. 081 Rev. A

### Alternator Castellated Hex-Nut Inspection

#### 1. Eligibility:

- A. Plane-Power alternators P/N ALT-9522(R), ALV-9510(R), ALV-9610, ALX-9524(R), C14-100(S), C28-150(S), ES-6024D, and ES-10024 manufactured by Hartzell Engine Technologies (HET) and shipped between 05 January 2011 and 21 May 2019 are affected by Alert Service Bulletin (ASB) 081 Rev. A.
  - (1) Engine model/series affected are shown in Table 2 of ASB 081 Rev. A.

#### 2. Commercial Assistance Program:

The following will be provided with the submission of a completed ASB 081 Claim Form, copies of invoices showing breakdown of material and labor charges, and log book entries. **Any commercial assistance or other consideration shall expire twelve (12) calendar months from the original published date of Alert Service Bulletin No. 081 Rev. A.**

- A. Required material listed in section 2 of ASB 081 Rev. A.
- B. Labor for inspection, removal, & installation compliance with ASB 081 Rev. A on affected alternator will be paid at a shop rate of \$75 an hour up to the amount specified below:
  - (1) Up to one (1.0) man-hour of labor is needed for removal, inspection, and installation of the alternator if replacement of castellated hex-nut **is not** required.
  - (2) Up to two (2.0) man-hours of labor are needed for removal, inspection, and installation of the alternator if replacement of castellated hex-nut **is** required.

#### 3. Commercial Assistance ADMINISTRATION:

- A. Complete the Service Bulletin ASB 081 Claim Form attached to this appendix.
  - (1) Mail, e-mail, or fax the ASB 081 Claim Form to the attention of Product Support as indicated on the Alert Service Bulletin Claim Form.
- B. Upon receipt of the Alert Service Bulletin Claim Form, Hartzell Engine Technologies LLC HET will:
  - (1) Ship the required material in accordance with section 2 (HET parts) to the service provider indicated.
  - (2) The service provider must return proof of service within thirty (30) days or the service provider shall be invoiced for the HET supplied materials.
- C. For labor and Continental Aerospace Technologies' parts listed in section 2:
  - (1) Aircraft/engine service facility or owner must submit an invoice up to the amount specified in section 2, copies of logbook entries, and a completed ASB 081 Claim Form for reimbursement (*May be a copy of the original form provided*).

# Alert Service Bulletin Appendix

## Alert Service Bulletin No. 081 Rev. A

### **Alternator Castellated Hex-Nut Inspection**

#### **4. WARRANTY STATEMENT:**

- A The sole warranty for the actions of ASB 081 Rev. A are contained in the HET Limited Warranty Policy issued with the purchase of each new/overhauled alternators (see terms and conditions therein).
- B. Commercial assistance may apply as stated in this Appendix.
- C. Issuance of ASB 081 Rev. A in no way constitutes an implied or expressed warranty of any kind.
- D. This publication does not imply or state any responsibility for the workmanship of any person or entity performing work or maintenance on the engine or aircraft electrical system.

#### **5. CONTACT INFORMATION:**

- A. Contact HET Product Support for all communications regarding the technical content of this Service Bulletin.
  - (1) Phone +1.334.386.5400 (Option 2)
  - (2) Fax +1.334.386.5410.
  - (3) E-mail at [techsupport@HartzellEngineTech.com](mailto:techsupport@HartzellEngineTech.com).
  - (4) Address  
Hartzell Engine Technologies LLC  
2900 Selma Highway,  
Montgomery, AL 36108  
USA

# Alert Service Bulletin Appendix

## Alert Service Bulletin No. 081 Rev. A

### Alternator Castellated Hex-Nut Inspection

#### ASB 081 CLAIM FORM

#### Owner information

Name: \_\_\_\_\_ Date: \_\_\_\_\_ Tel: \_\_\_\_\_ Fax: \_\_\_\_\_

Company Name: \_\_\_\_\_ E-mail: \_\_\_\_\_

Address: \_\_\_\_\_

City: \_\_\_\_\_ State: \_\_\_\_\_ Postal Code: \_\_\_\_\_

Country: \_\_\_\_\_

#### Aircraft/Engine Service Facility information

Name: \_\_\_\_\_ Date: \_\_\_\_\_ Tel: \_\_\_\_\_ Fax: \_\_\_\_\_

Company Name: \_\_\_\_\_ E-mail: \_\_\_\_\_

Address: \_\_\_\_\_

City: \_\_\_\_\_ State: \_\_\_\_\_ Postal Code: \_\_\_\_\_

Country: \_\_\_\_\_

Aircraft Mfg: \_\_\_\_\_ Model: \_\_\_\_\_ Time in Service: \_\_\_\_\_ S/N: \_\_\_\_\_

Engine: \_\_\_\_\_ Model: \_\_\_\_\_ Time in Service: \_\_\_\_\_ S/N: \_\_\_\_\_

#### Component Information

Nomenclature: Alternator \_\_\_\_\_ Part Number: \_\_\_\_\_

Serial Number: \_\_\_\_\_ (Alternator) Date Removed: \_\_\_\_\_

Part Time in Service: \_\_\_\_\_ (Alternator) Original Date Installed: \_\_\_\_\_

For RMA Number

Send this ASB 081 Claim Form to:

Hartzell Engine Technologies Product Support

Fax: +1.334.386.5410

E-mail: techsupport@hartzellenginetech.com

#### RMA Number:

(write in HET assigned RMA number)

**Hartzell Use Only - do not write below this line.**

Warranty No: \_\_\_\_\_ Authorized by: \_\_\_\_\_

